

Montageanleitung  
Installation instructions



# LIBATO\_HOS



A	4 x	
B	4 x	
C	1 x	
D	8 x	
E	4 x	
F	8 x	
G, H	4 x	
I	2 x	
J	4 x	
K	2 x	
L	4 x	

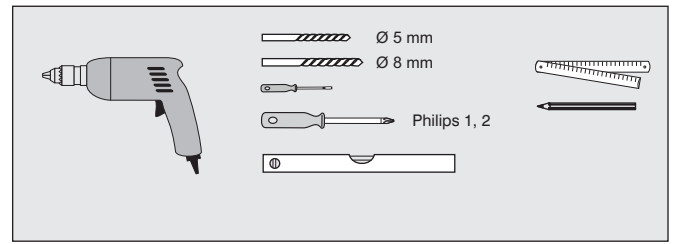

- I - LIBATO\_HOS
- II - LIBATO\_SPIEGEL
- III - LIBATO\_WTU

Nummerierung entspricht der empfohlenen Montagereihenfolge./  
The numbering corresponds to the assembly sequence recommended.

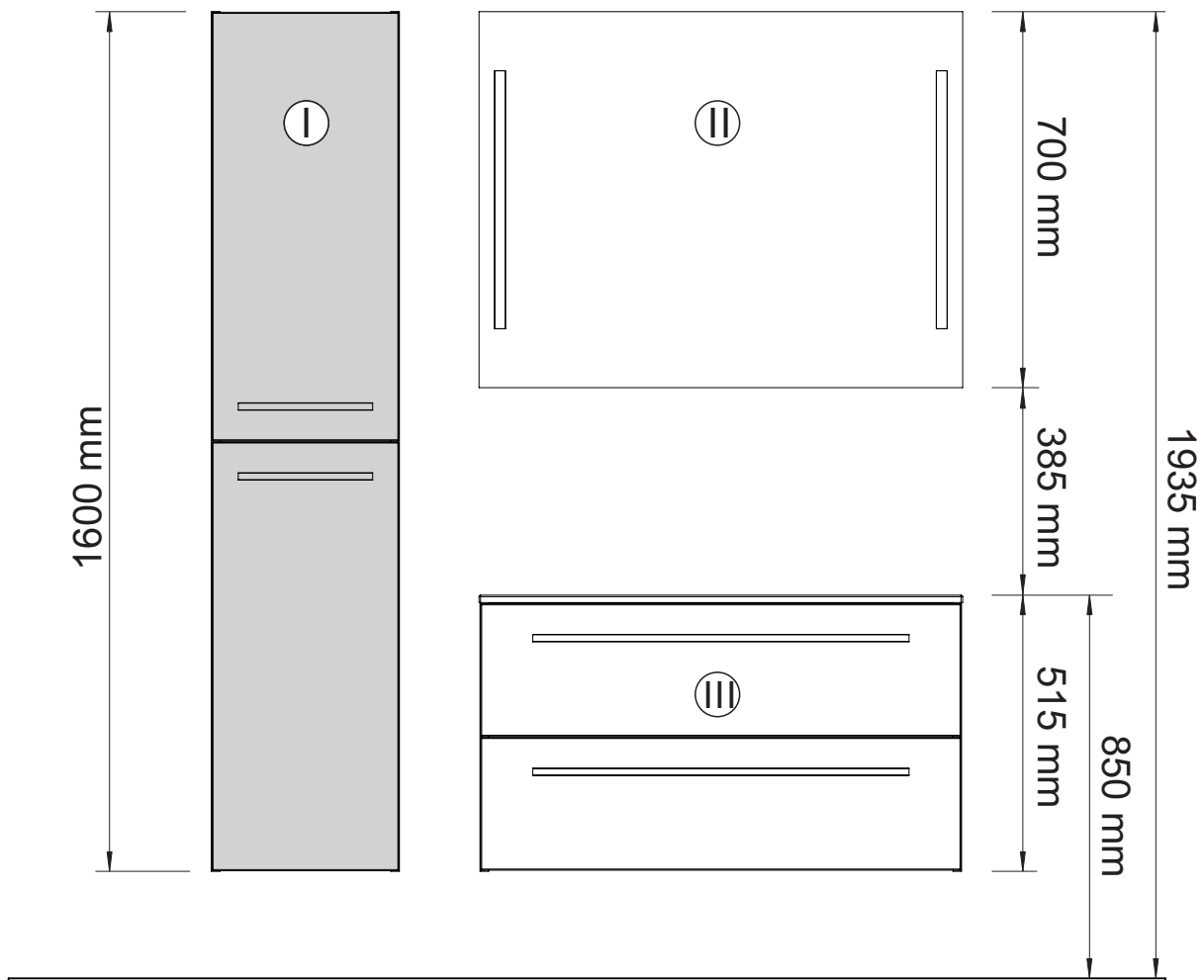

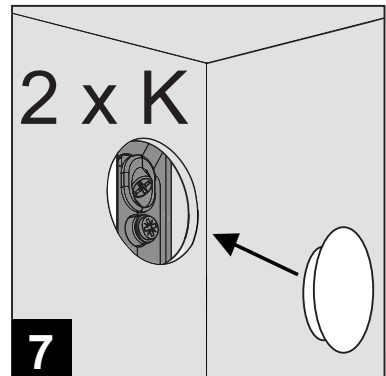
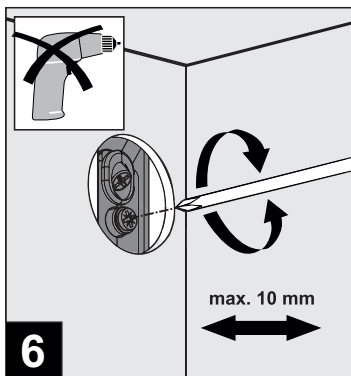
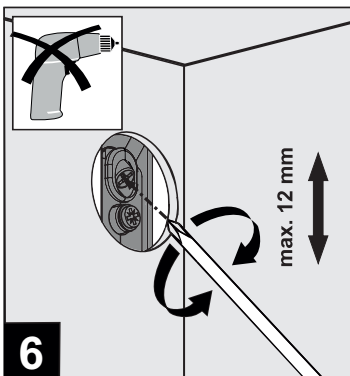
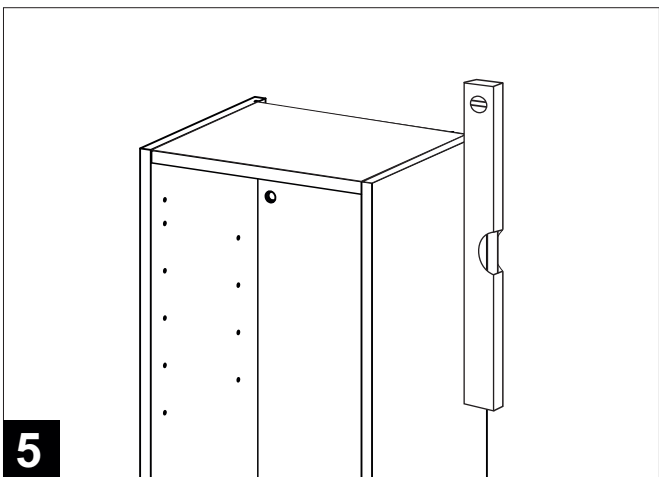
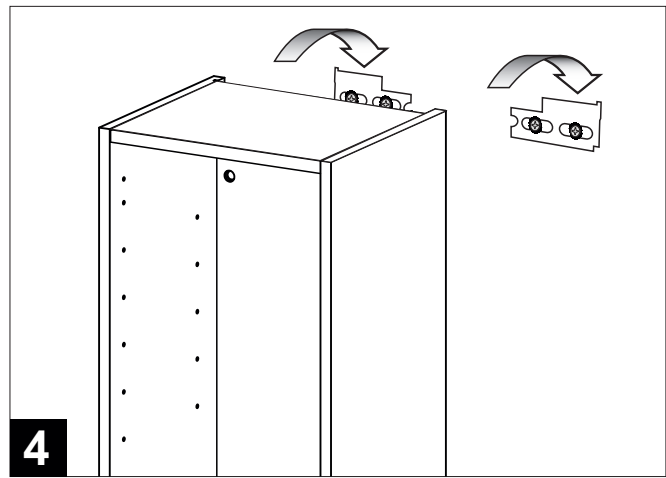
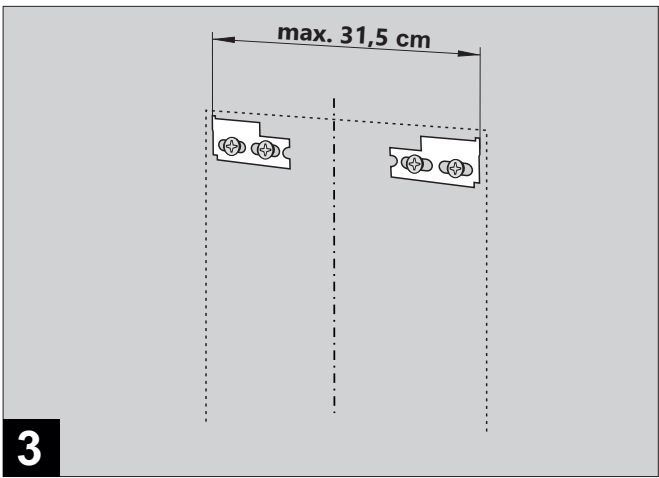
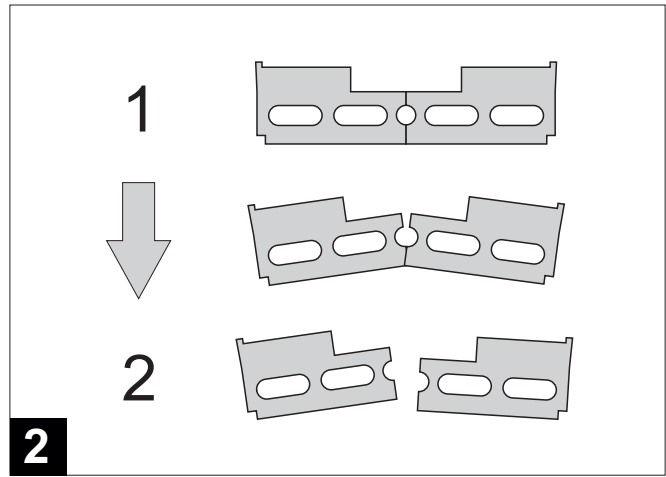
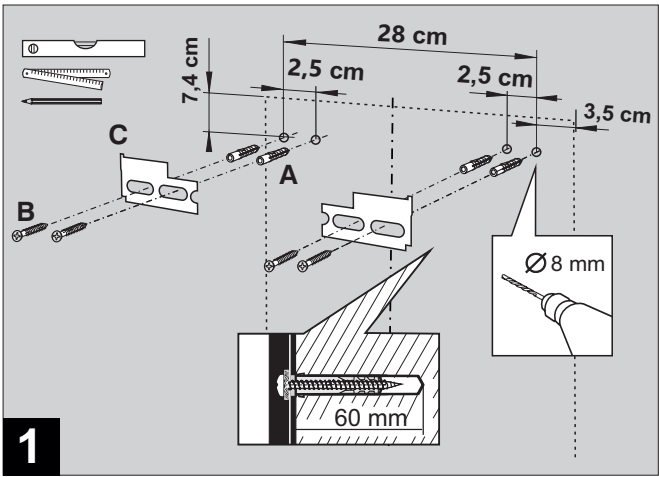

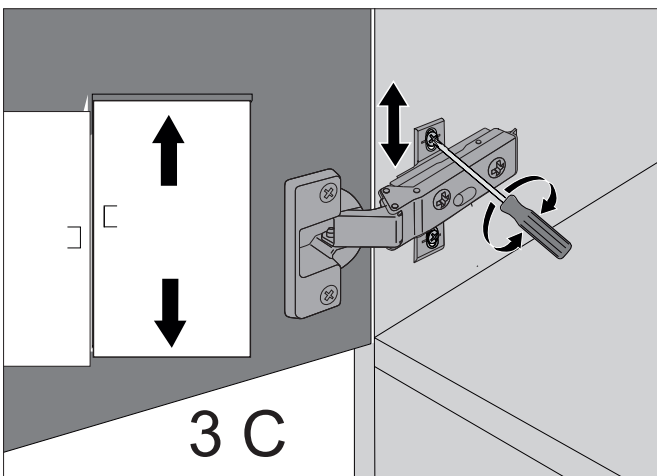
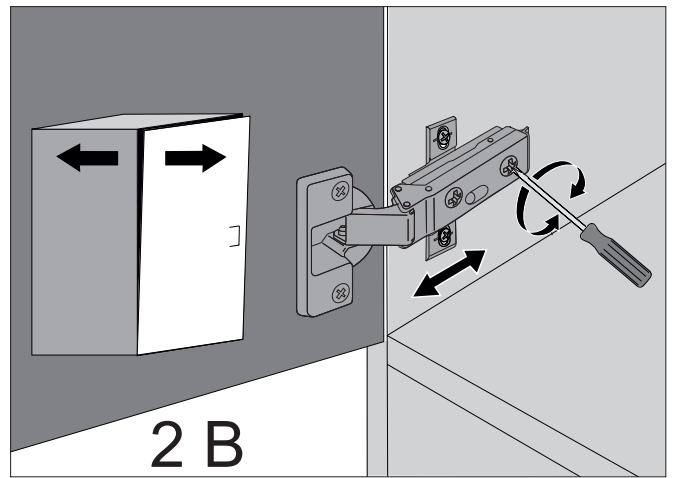
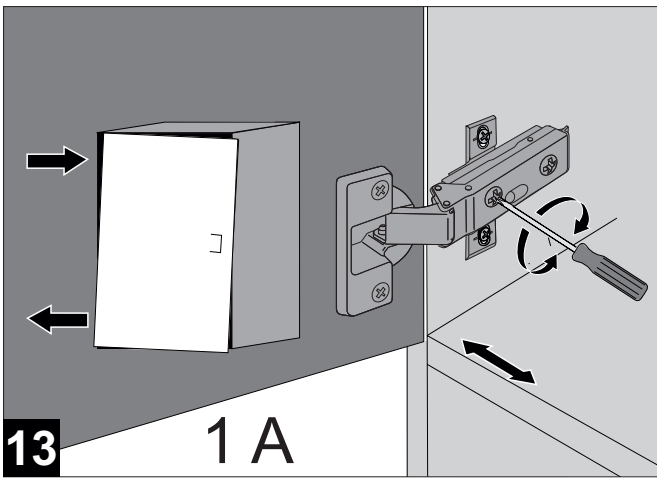
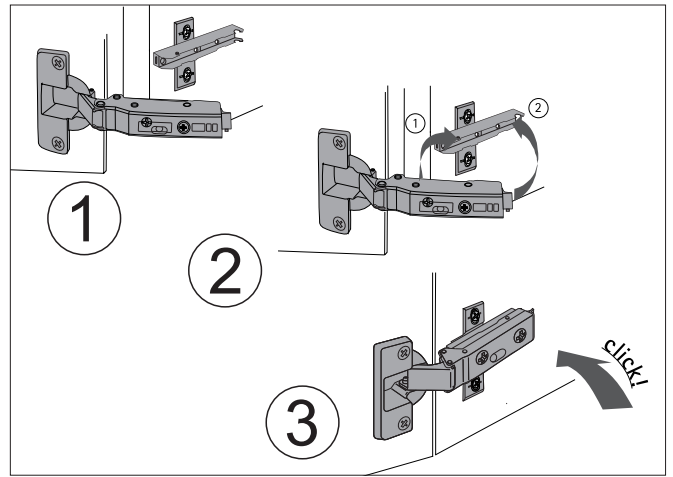
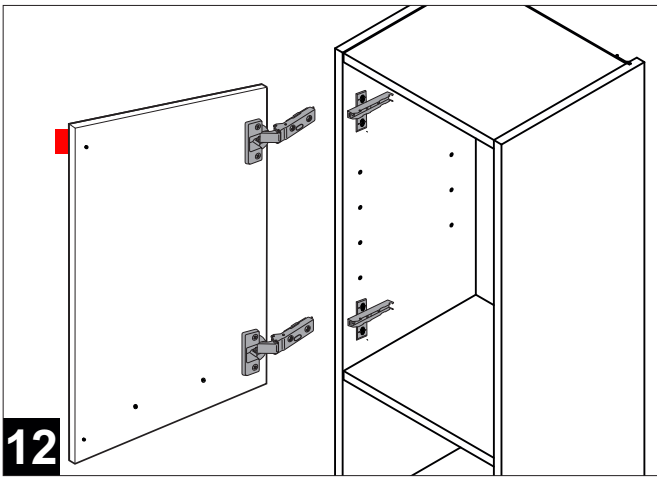

**Türscharniere „abklippen“**  
free the door hinges

**Dämpfung**

**Dämpfung einstellen: adjust damping:**

- kräftig / strong**
- mittel / medium**
- empfohlen / commended:**
- schwach / light**

**1.** **Türscharnier wieder aufklippen / fix the door hinges**

**2.**

**(14)**

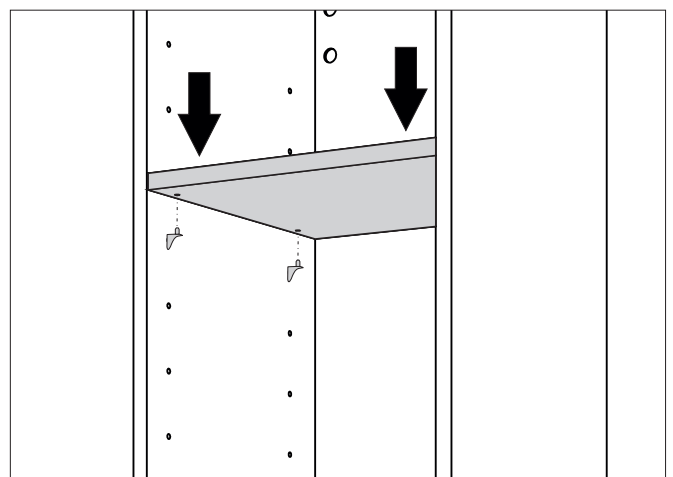
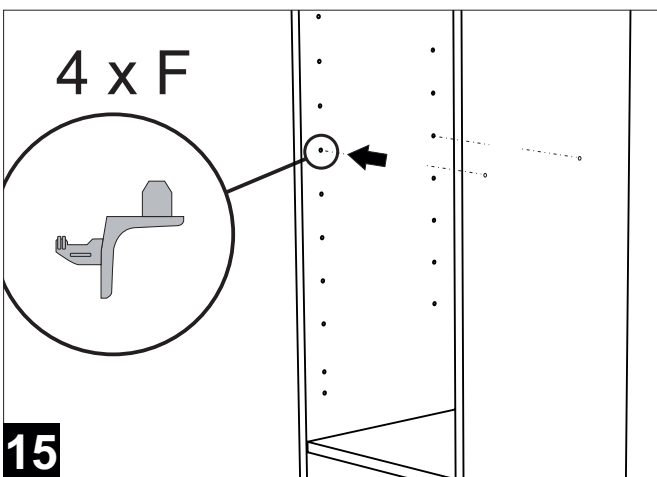



### Bitte beachten :

Die Möbelfronten können links oder rechts angeschlagen werden. Bitte beachten Sie, je nach Ihrer persönlichen Einbausituation, auf welcher Korpusseite Sie die Montageplatten anbringen möchten und wo Sie die entsprechenden Bohrungen zur Griffbefestigung setzen.

Um Beschädigungen zu vermeiden wird für die Griffbohrungen geeignetes Unterlagematerial (z.B.Holz) benötigt.

### Attention :

Furniture doors can be fixed at both cabinet sides. Please take care, dependent on your personal installation circumstances, at which side do you fix the mounting plates and where do you place the handle drilling.

In order to guard against damage, please use unified drilling support (for example „wood“).

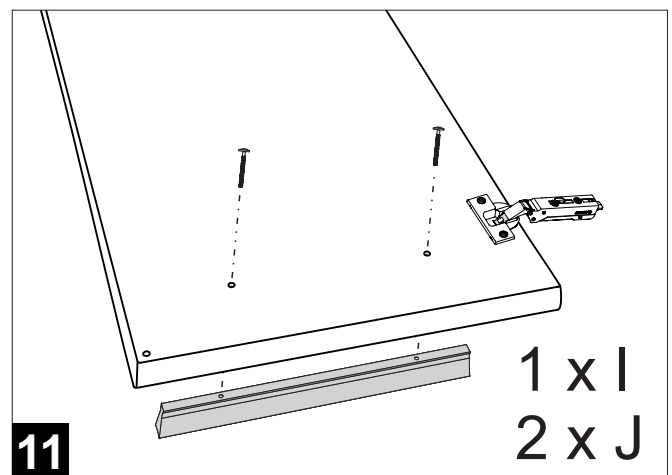
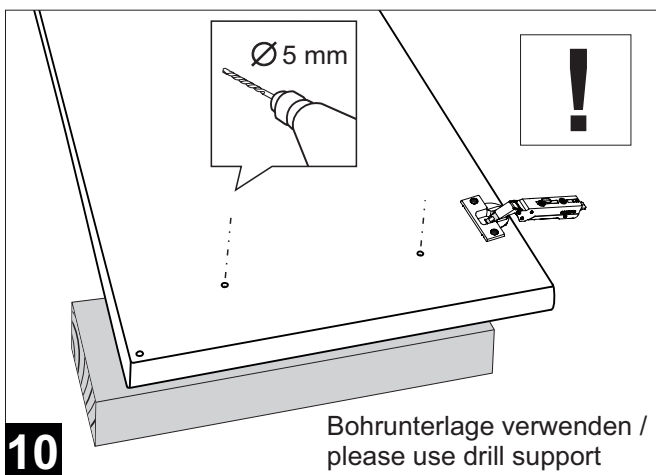
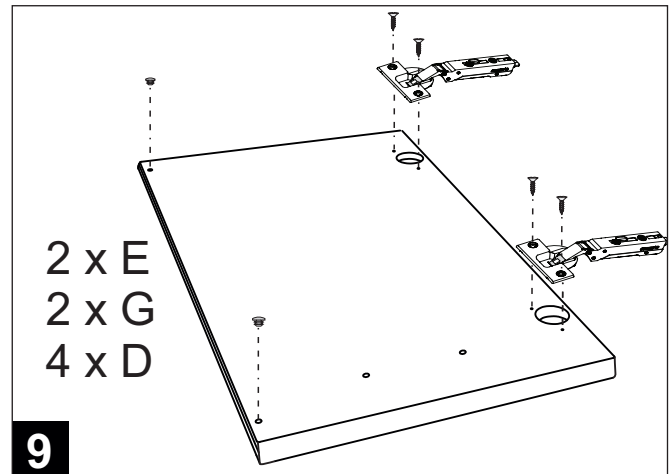
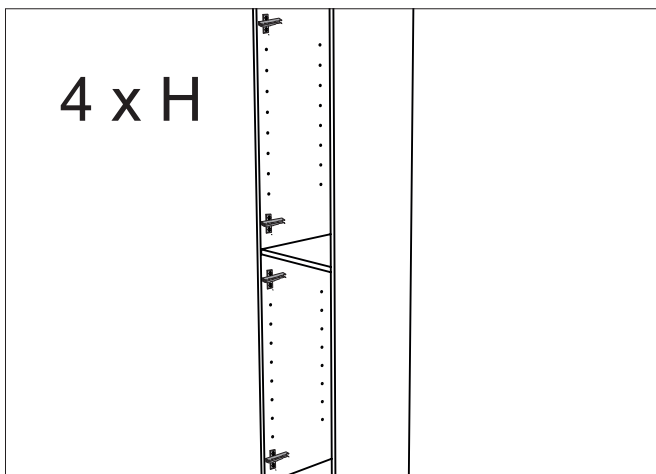
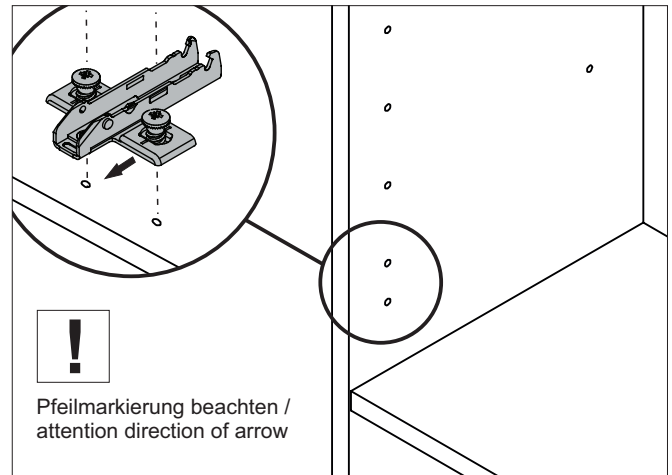
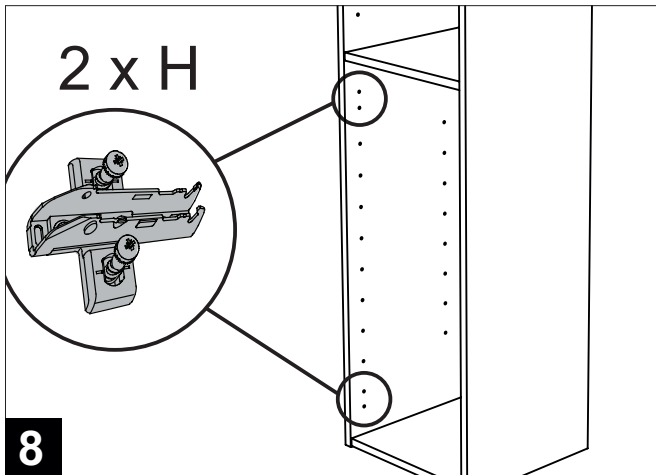
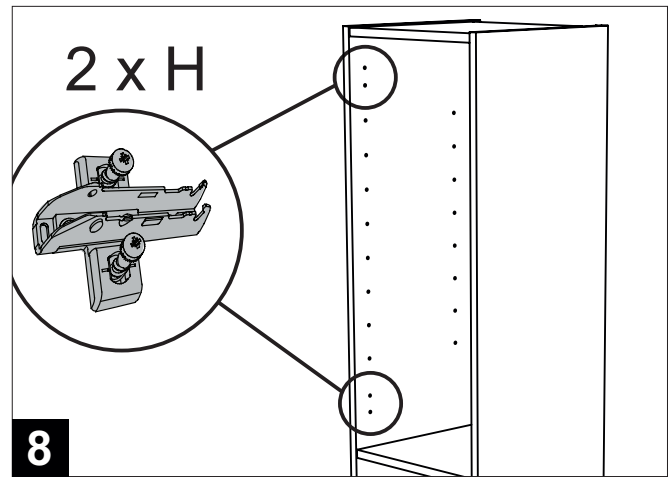

# LIBATO\_WTU



A	6 x	
B	6 x	
C	1 x	
D	2 x	
E	2 x	
F	4 (6) x	

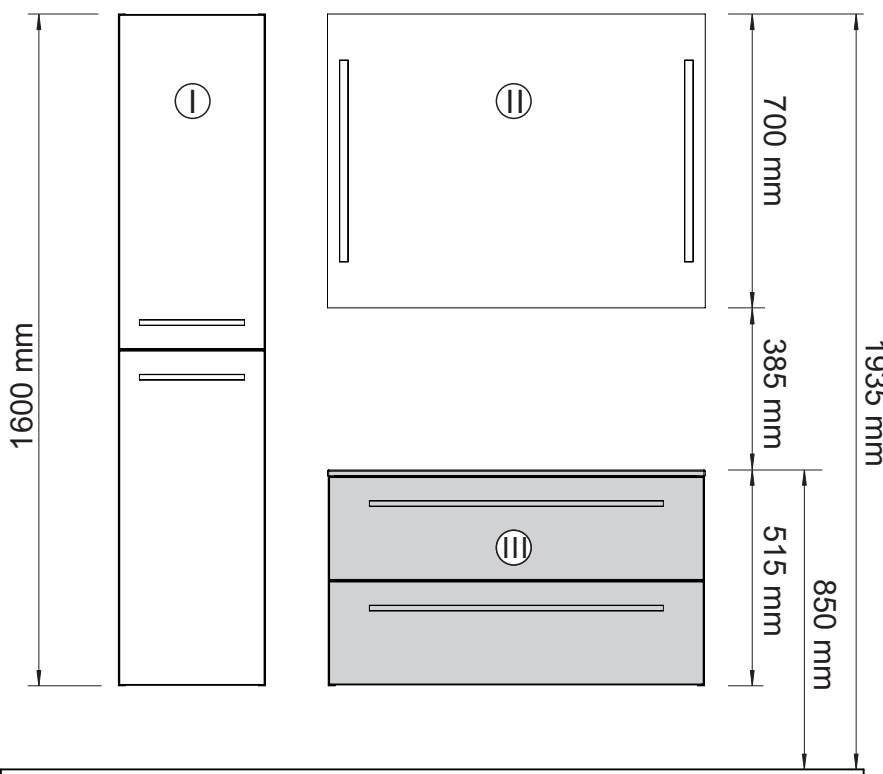
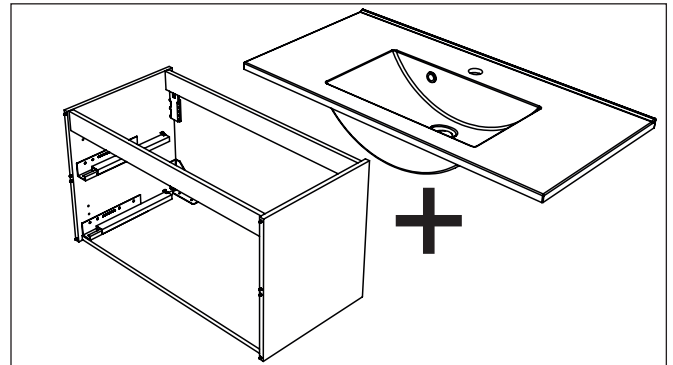
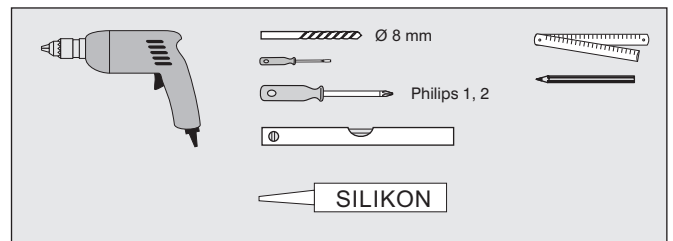

- I - LIBATO\_HOS
- II - LIBATO\_SPIEGEL
- III - LIBATO\_WTU

Nummerierung entspricht der empfohlenen Montager Reihenfolge./  
The numbering corresponds to the assembly sequence recommended.

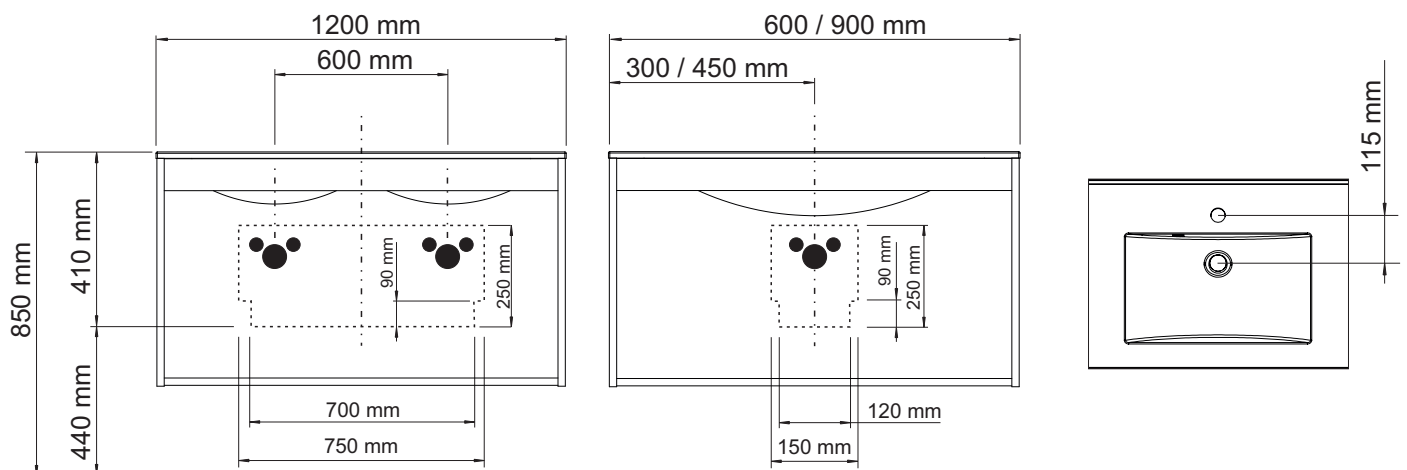

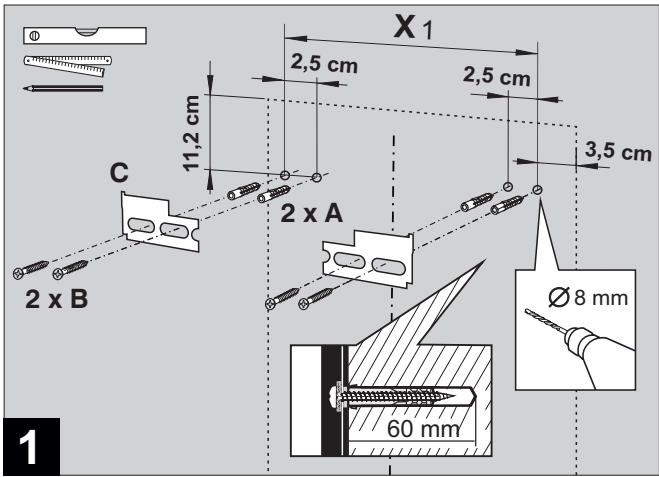

	Libato_WTU 60	Libato_WTU 90	Libato_WTU 120
<b>X1</b> in cm	52,5	82,5	112,5
<b>X2</b> in cm	56	86	116

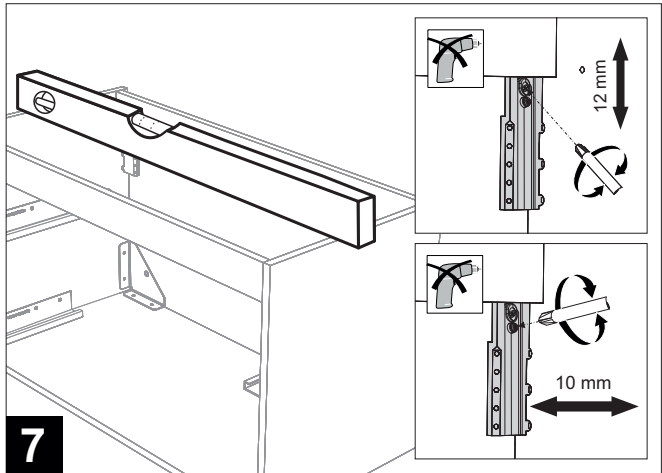
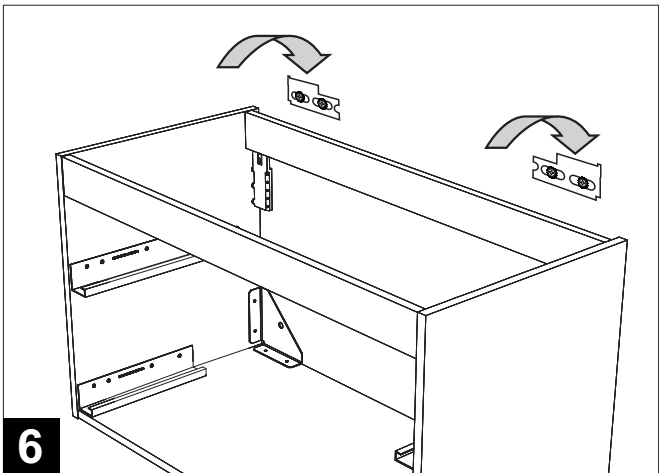
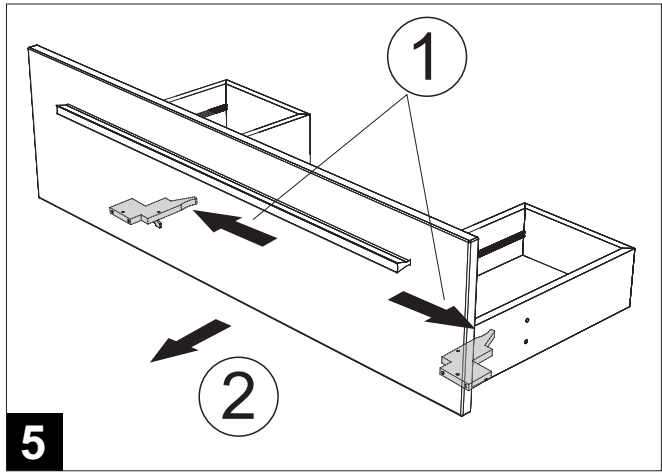
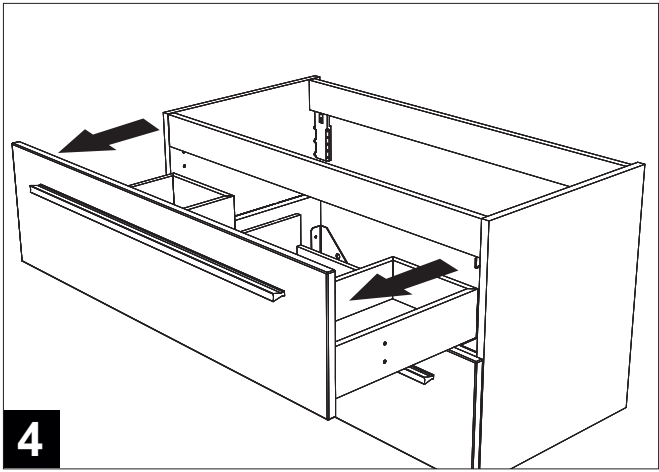
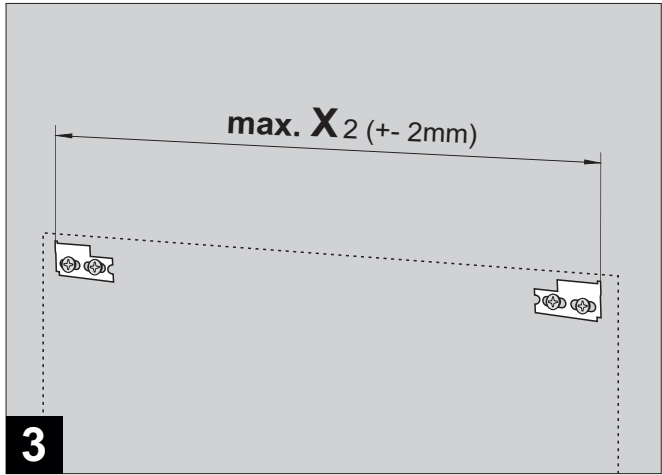
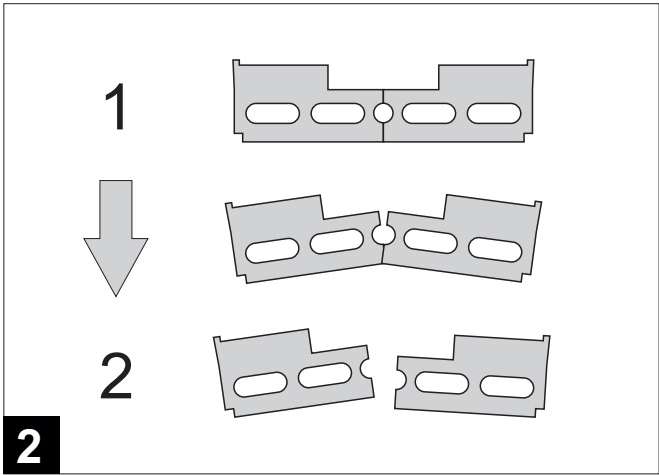

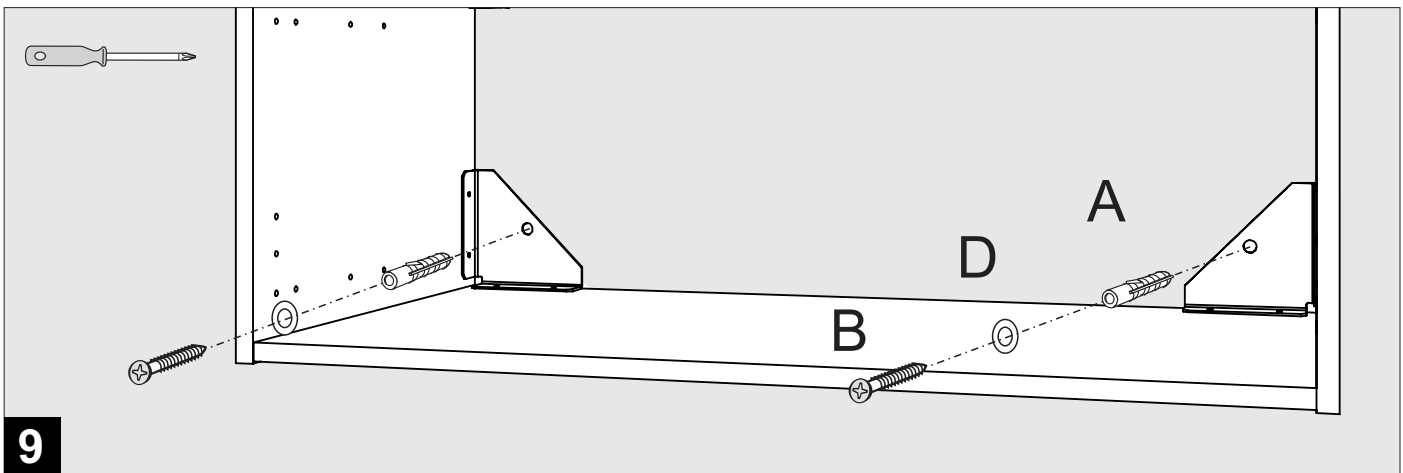
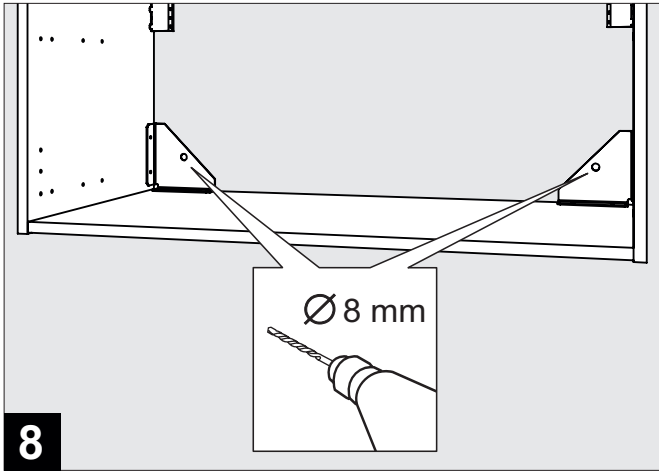

**Bitte beachten :**

Waschtischplatte vor der Montage (Silikon) bitte unbedingt auf eventuelle Transportschäden untersuchen. Reklamationen von bereits verklebten Platten können nicht mehr anerkannt werden. Beim Befestigen mit Silikon bitte nicht vollflächig auftragen, sondern nur sparsam auf die Korpusoberseite. Durch Aufschneiden des Silikonkautschuks kann die Waschtischplatte auf diese Weise später wieder abgenommen werden (z. B. bei Umzug...).

**Attention :**

Please check the washbasin for damage before you fix it with silicone. Already fixed washbasins cannot be claimed. Don't apply silicone all over the cabinet, please apply only a little on the cabinet topside. If you cut the silicone later you can easy remove the washbasin. (for example: for move).

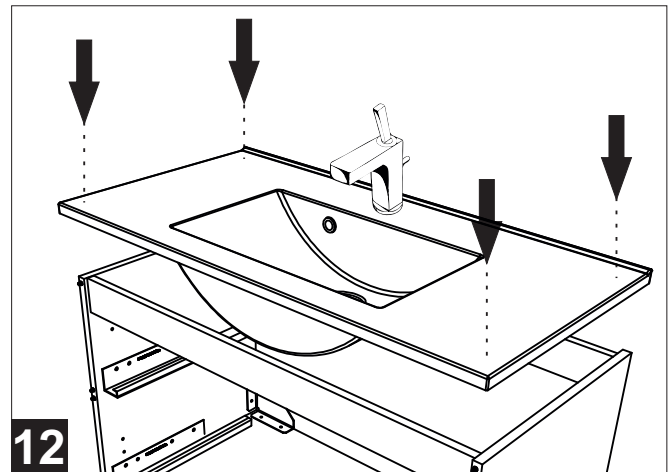
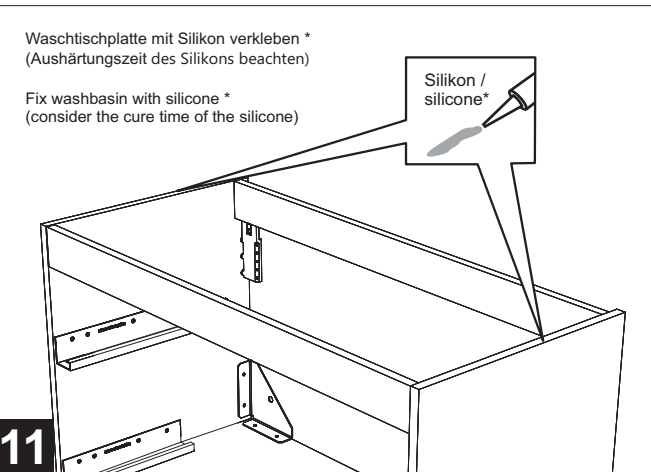
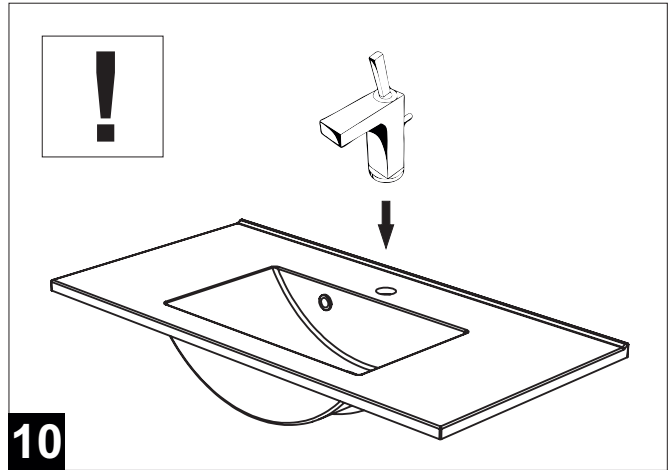



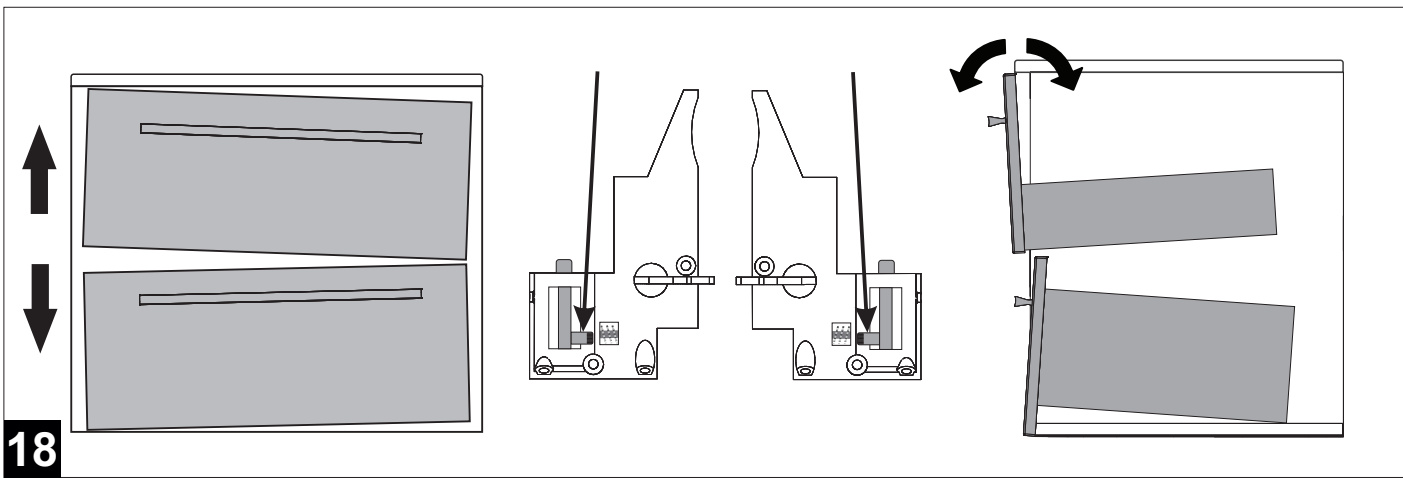
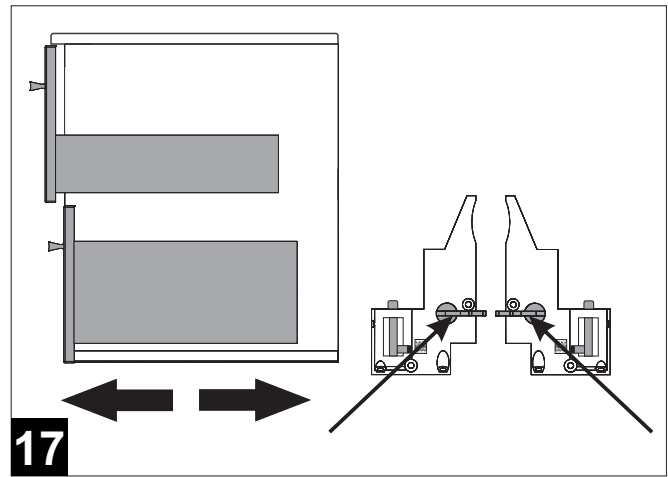
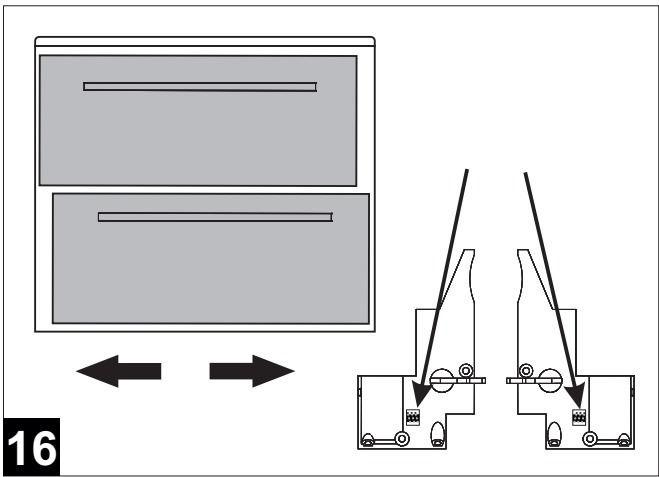
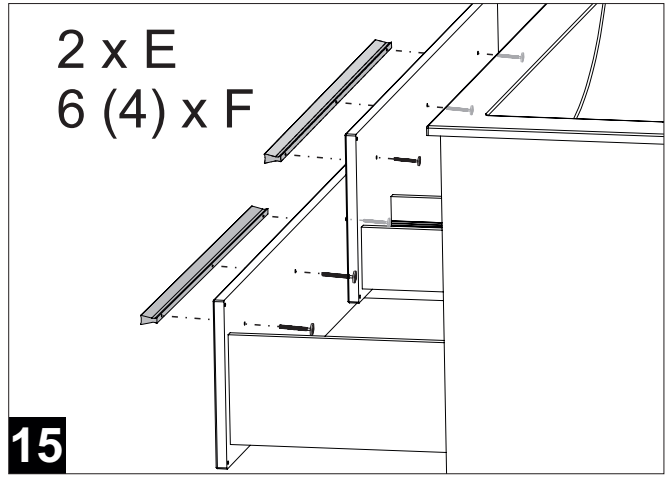
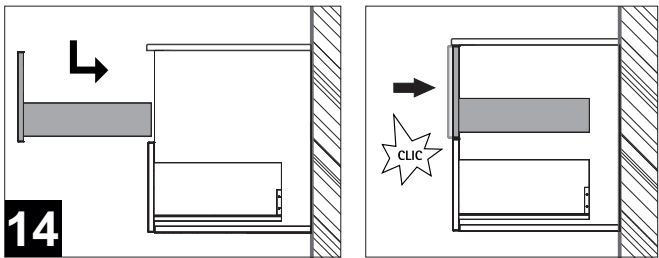
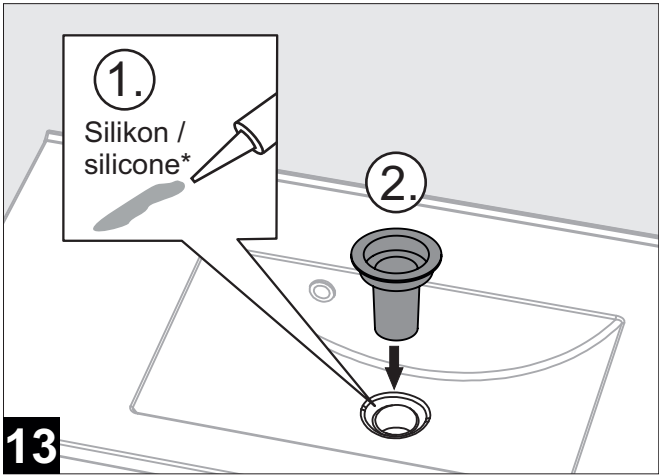

## Pflege, Reinigung, Garantie

**Pflege, Reinigung:** Oberflächen nur mit einem feuchten Tuch reinigen, evtl. milden Allzweckreiniger verwenden. Keine scheuernden oder lösungsmittelhaltigen Reinigungsmittel oder scheuernden Schwämme benutzen. Alu-Schränke: keine Säuren! Kristallglasspiegel nur mit einem weichen Tuch reinigen. Hartnäckigen Schmutz hier mit klarem Wasser und ausgewrungenem Leder beseitigen. Bitte für Spiegel niemals chemische Reinigungsmittel verwenden. **Garantie:** Für unsere Erzeugnisse gewähren wir ab Verkaufstag eine Garantie von 2 Jahren. Ausgeschlossen von dieser Garantie sind Schäden durch nicht fachgerechte Montage, unsachgemäße Behandlung sowie Verschleißteile wie Lampen und Starter. Bei Reparaturen bitte nur Originalteile verwenden, Elektroreparaturen nur vom Elektrofachmann ausführen lassen, keine Änderungen am Erzeugnis vornehmen! Ansonsten müssen wir jede Haftung ablehnen, der Garantieanspruch geht verloren. Unser Kundendienst hilft Ihnen bei Problemen. Für Hinweise und Anregungen sind wir immer offen. Änderungen und Irrtümer vorbehalten.

## Care, cleaning, guarantee

**Care and Cleaning** Only use a damp cloth to clean the surfaces, if necessary with a mild all-purpose cleaning liquid. Do not use any scouring detergents, detergents that contain solvents or abrasive sponges. Aluminium cabinets: no acids! The crystal glass mirror may only be cleaned with a soft cloth. Remove stubborn dirt with clear water and a wrung-out chamois leather. Please never use chemical detergents on the mirrors. **Guarantee:** We guarantee our products for 2 years from the date of purchase. Damage caused by improper handling or incorrect installation and expendable parts such as bulbs and starter switches are excluded from the guarantee. Only genuine parts may be used for repairs. Electric repairs may only be done by qualified electricians. Do not make any alterations to the product. Otherwise, we shall cease to be liable and warranty claims will not be accepted. Our customer support will help you have any problems. We are always grateful for information and suggestions from customers.

Subject to alterations. Errors excepted.

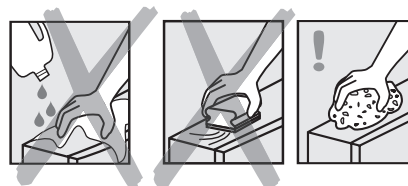

Bei Reklamationen diesen Abschnitt (Kopie) **zusammen mit dem Kaufbeleg** an Jokey schicken. If there is a problem send this coupon (or copy) **together with the receipt** back to Jokey.

QS

→ Jokey Service

430714261

21 93200 Libato Hochschrank / 03 / 2023

21 93250/251/252 Libato 60 / 90 / 120 Waschtischunterschrank

Jokey Sohland GmbH Service  
Industriestr. 4  
D - 02689 Sohland / Spree

Tel.: +49(0)35936 / 36-0  
**Tel. Service:** +49(0)35936 / 36-2265  
email: [js.service@jokey.com](mailto:js.service@jokey.com)  
Fax: +49(0)35936 / 36-2222  
**Fax Service:** +49(0)35936 / 36-2281

<http://www.jokey-online.com>





